

MR.General

Manual NO.RS002

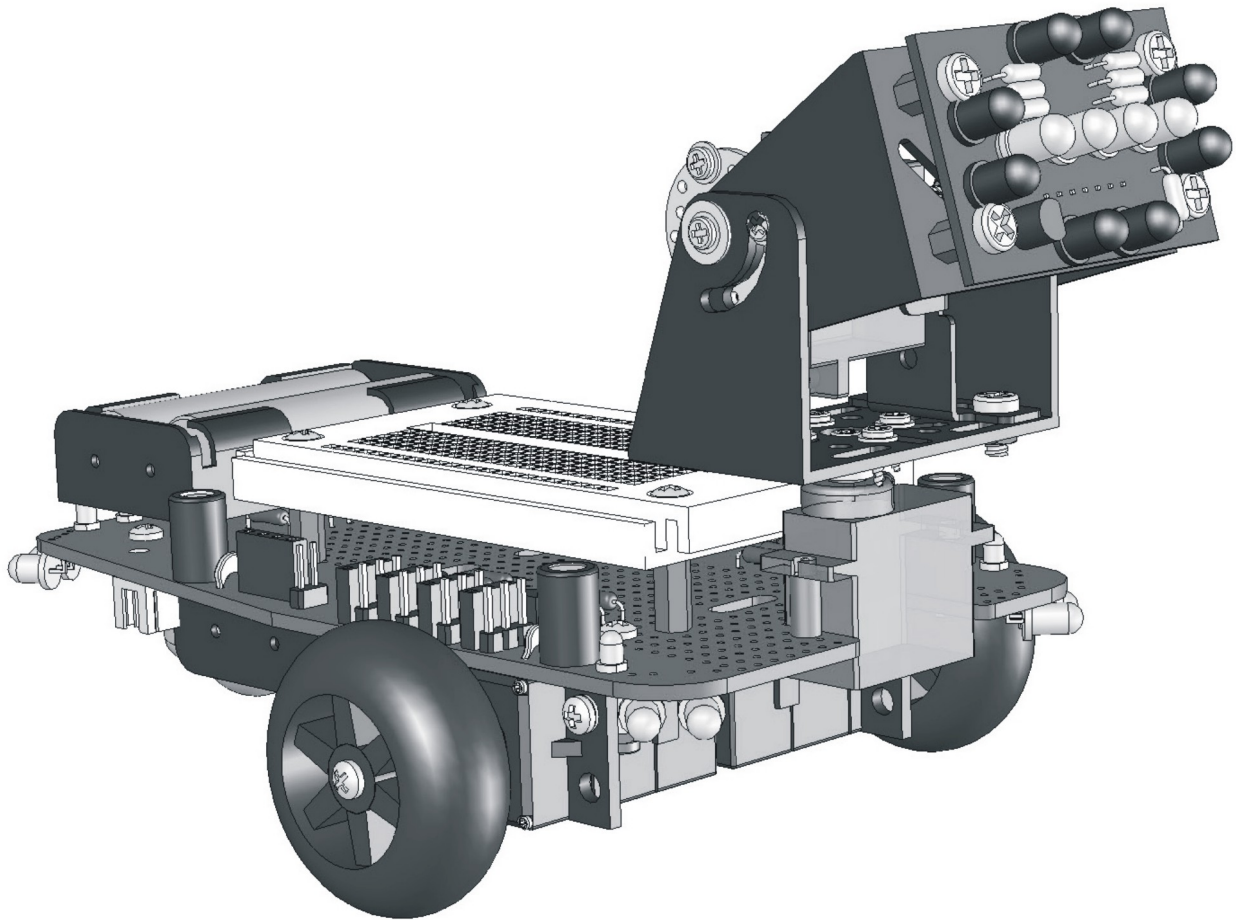

Copyright ©2009 by DAGU Hi-tech Electronic Co., Ltd.

All rights reserved. No portion of this instruction sheet or any artwork contained herein may be reproduced in any shape or form without the express written consent of DAGU Hi-tech Electronic Co., Ltd.

The manufacturer and distributor cannot be held responsible for any damages occurred by mishandling, mounting mistakes or misuse due to non-respect of the instructions contained in this manual.



Manufacturer:
DAGU Hi-Tech Electronic Co.,LTD
WWW.AREXX.COM.CN



European Importer:
AREXX Engineering
ZWOLLE, HOLLAND

© DAGU CHINA

Address:NO.4-107/108 HengXing Street, HengHai Rd, South District, ZhongShan City of GuangDong China

TEL:0760-88811951

<http://www.arexx.com.cn>

E-mail:info@arexx.com.cn

PRODUCT DESCRIPTION:

Thanks for selecting of our product Mr.General, which is designed as a general purpose learning platform for students and hobbyist alike.

PRODUCT FEATURES

- 1.Abundant sensors and special servos make it easy to use and fun to experiment with.
- 2.The base PCB has prototype areas for additional sensors and circuitry.
- 3.The breadboard allows many different processors to be used easily.

Build it now! Realize your dream! Create your next masterpiece!



Warnings:

- No return is possible after having opened the bags with components and pieces.
- Prior to the assembly read the manual thoroughly.
- Be careful when using tools.
- Keep this kit away from young children during construction and operation. (They might get hurt by the tools or swallow small components).
- Observe the correct polarity of the battery.
- Keep dry. When the Mr.general gets wet DO NOT USE.Remove batteries immediately.
- Let the robot dry completely before re-using.
- If it is not used for a long time, remove the battery.

Necessary Tools:

Before you start assembling we suggest you first read the manual thoroughly. Please follow the asssembling instructions precisely to avoid problems. Incorrect assembly will result in poor operation

Before you start you will require the following tools:

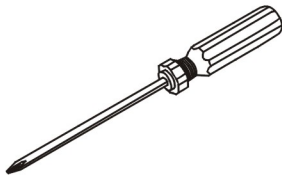

Phillips screwdriver (supplied)

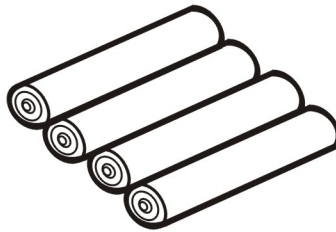

AA batteries

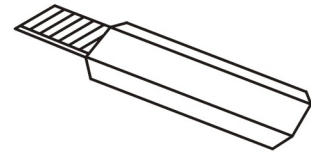

Sharp Knife

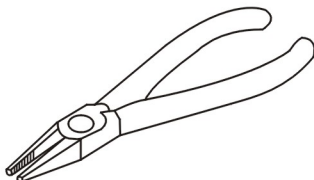

Longnose plier

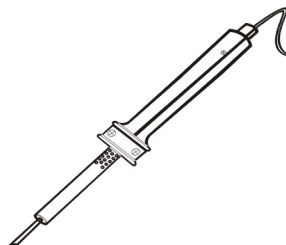

Soldering Iron

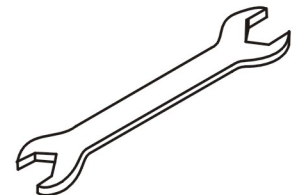



Hex wrench (supplied)

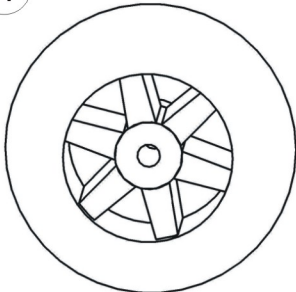
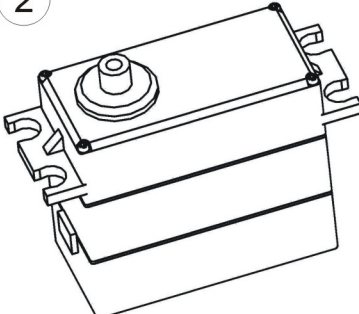
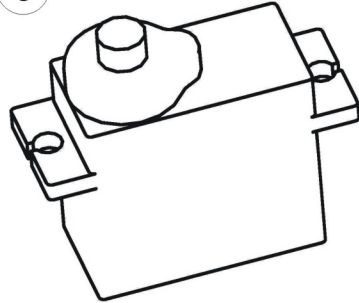
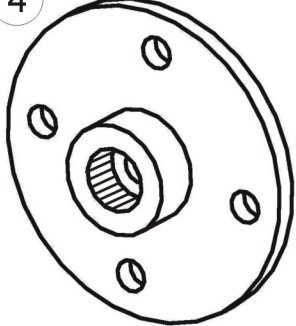
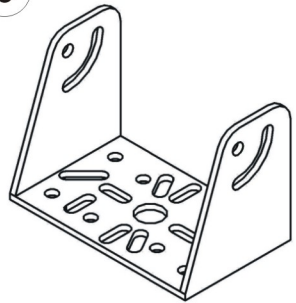
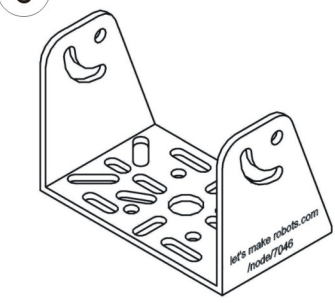
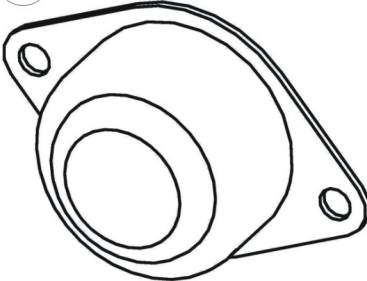
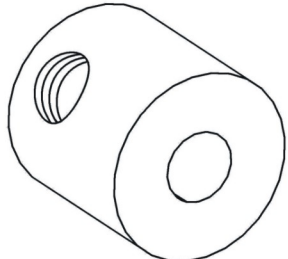
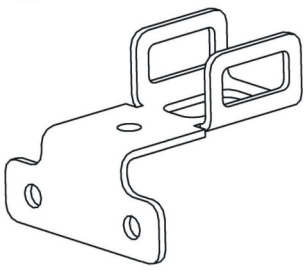
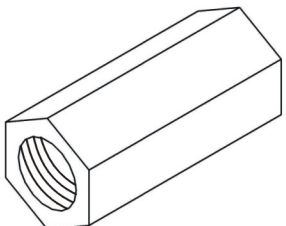
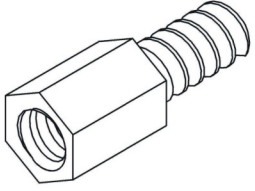
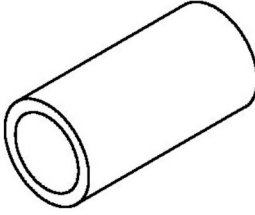
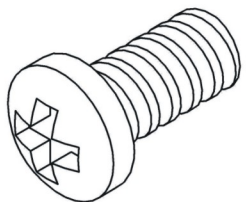
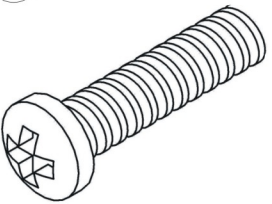
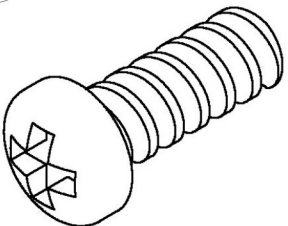
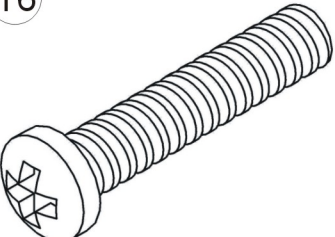
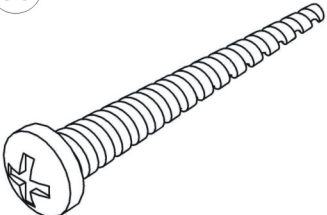
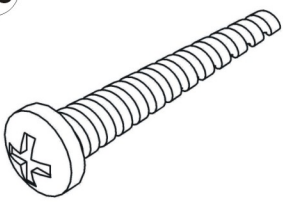
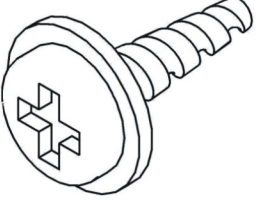
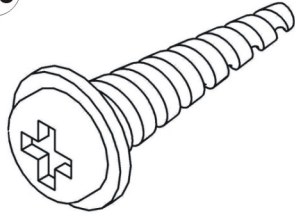
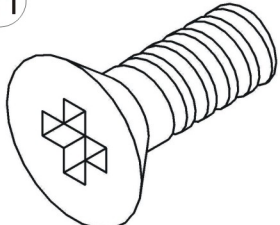

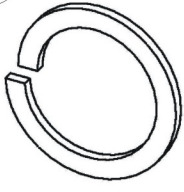
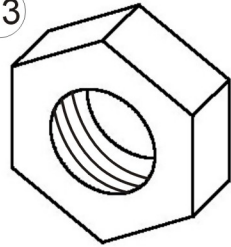
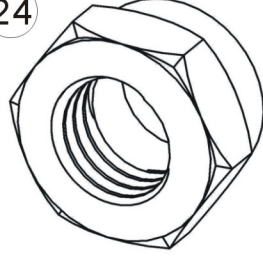
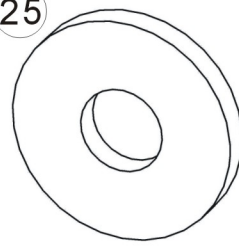
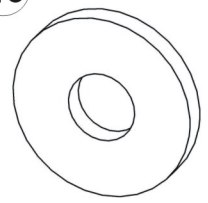







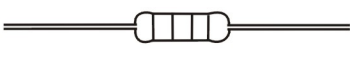



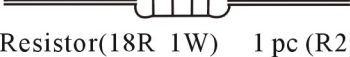
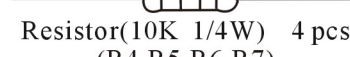



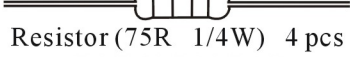



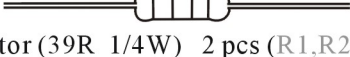

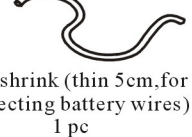
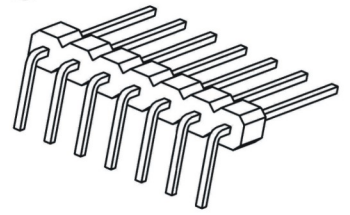
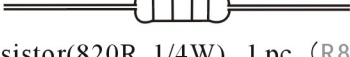
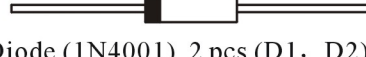
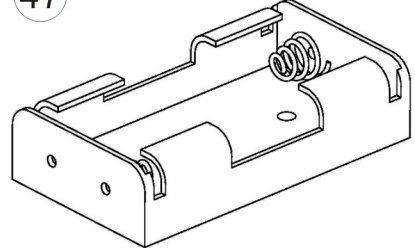

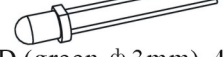
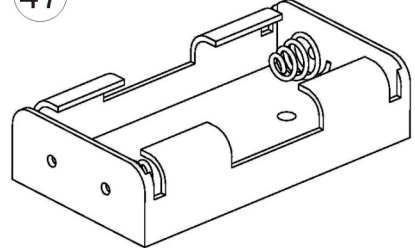

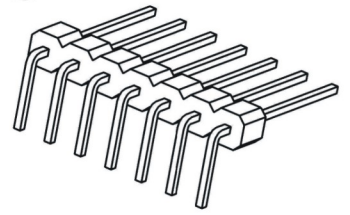
Components list 1 (Hardware and plastic parts)

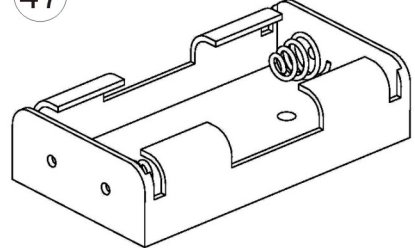
<p>1</p>  <p>Wheels 2 pcs</p>	<p>2</p>  <p>Modified servo 2 pcs</p>	<p>3</p>  <p>Miniature servo 2 pcs</p>	<p>4</p>  <p>Servo horn 2 pcs</p>	
<p>5</p>  <p>Sensor mounting bracket 1 1 pc</p>	<p>6</p>  <p>Sensor mounting bracket 2 1 pc</p>	<p>7</p>  <p>Ball caster 1 pc</p>	<p>8</p>  <p>Spacer (L10, Inner Diameter 3, Middle M3 Thread) 4 pcs</p>	
<p>9</p>  <p>Servo mounting bracket 1 pc</p>	<p>10</p>  <p>Hex spacer (female to female L10) 4 pcs</p>	<p>11</p>  <p>Hex spacer (female to male L6) 8 pcs</p>	<p>12</p>  <p>Round spacer (Inner 3, outer 4, L8) 2 pcs</p>	<p>13</p>  <p>Screw M3*6 12 pcs</p>
<p>14</p>  <p>Screw M3*12 1 pc</p>	<p>15</p>  <p>Screw M3*8 4 pcs</p>	<p>16</p>  <p>Screw M3*20 4 pcs</p>	<p>17</p>  <p>Self-tapping screw 2.6*18 2 pcs</p>	
<p>18</p>  <p>Self-tapping screw 2.6*12 2 pcs</p>	<p>19</p>  <p>Self-tapping screw pan head 2.0*6 7 pcs</p>	<p>20</p>  <p>Self-tapping screw pan head 2.3*10 1 pc</p>	<p>21</p>  <p>Flat head screw M3*6 4 pcs</p>	

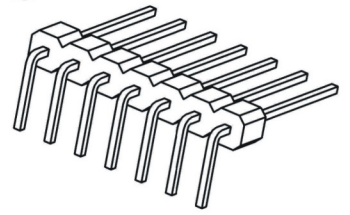
<p>22</p>  <p>M3 spring washer 4 pcs</p>	<p>23</p>  <p>M3 Nut 10 pcs</p>	<p>24</p>  <p>M3 Nylon nut 5 pcs</p>	<p>25</p>  <p>M3 Flat washer 4 pcs</p>	<p>26</p>  <p>Nylon washer 8 pcs</p>
--	---	--	---	--

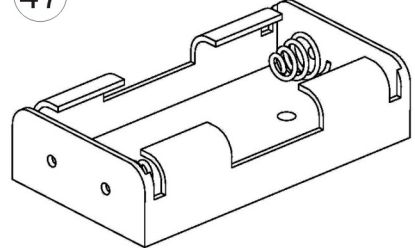
Components list 2 (Electronic parts):

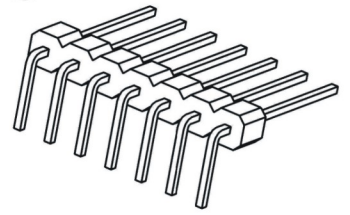
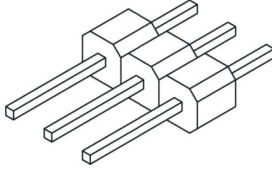
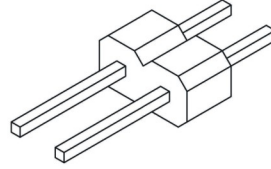
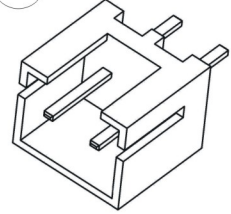
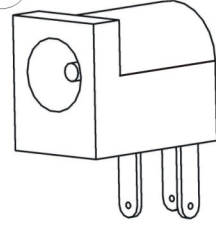
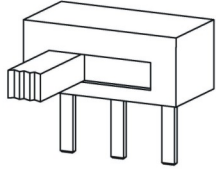
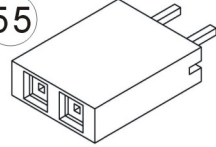
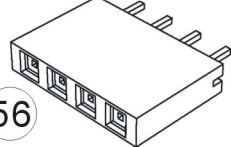
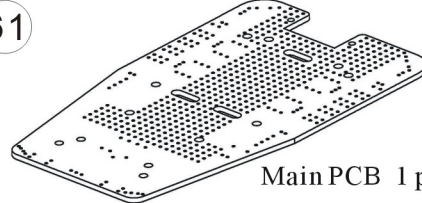
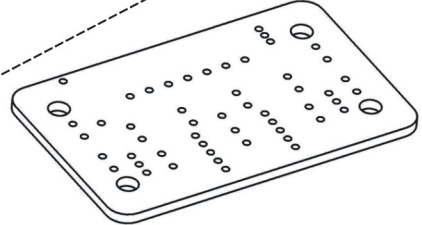
 Black marks indicate the parts should be used on Main PCB.
 Gray marks indicate the parts should be used on COMPOUND EYE PCB.

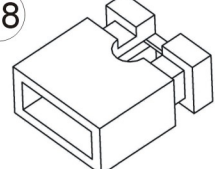
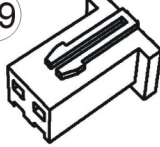
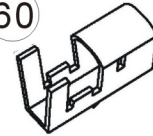
<p>27</p>  <p>Resistor(390R 1/4W) 1 pc (R1)</p>	<p>28</p>  <p>Resistor (180R 1/4W) 5 pcs (R3,R8,R10,R12,R14)</p>	<p>37</p>  <p>Electrolyze Capacitor (470 μ /16 V) 3 pcs (C1,C3,C5)</p>	<p>38</p>  <p>10uf capacitor 1pc</p>	
<p>29</p>  <p>Resistor(18R 1W) 1 pc (R2)</p>	<p>30</p>  <p>Resistor(10K 1/4W) 4 pcs (R4,R5,R6,R7)</p>	<p>39</p>  <p>Capacitor (0.22 μ) 3 pcs (C2,C4,C6)</p>	<p>40</p>  <p>Transistor (BC547TO92B) 4 pcs (Q5,Q6,Q7,Q8)</p>	<p>41</p>  <p>Transistor (PN100 TO92B) 1 pc (Q9)</p>
<p>31</p>  <p>Resistor (75R 1/4W) 4 pcs (R9,R11,R13,R15)</p>	<p>32</p>  <p>Resistor(2.2K 1/4W) 4 pcs (R16,R17,R18,R19)</p>	<p>42</p>  <p>IR LED(IR333C-A) 8 pcs (IR1,IR2,IR3,IR4)(LED1 .LED2.LED3.LED4)</p>	<p>43</p>  <p>Photo Transistor (PT334-6B) 12 pcs (Q1,Q2,Q3,Q4)(Q1, Q2, Q3, Q4, Q5, Q6, Q7, Q8)</p>	
<p>33</p>  <p>Resistor (39R 1/4W) 2 pcs (R1,R2)</p>	<p>34</p>  <p>Resistor (4.7K 1/4W) 4 pcs (R3,R4,R5,R6)</p>	<p>48</p>  <p>Heat shrink (thin 5cm,for connecting battery wires) 1 pc</p>	<p>49</p>  <p>7 Pin right-angle male header 1 pc (J1)</p>	
<p>35</p>  <p>Resistor(820R 1/4W) 1 pc (R8)</p>	<p>36</p>  <p>Diode (1N4001) 2 pcs (D1, D2)</p>	<p>47</p>  <p>Battery box 2 pcs</p>	<p>48</p>  <p>Heat shrink (thick 10cm, for covering the IR sensors) 1 pc</p>	
<p>44</p>  <p>LED (green φ 3mm) 4 pcs (LED3,LED4,LED5,LED6)</p>	<p>47</p>  <p>Battery box 2 pcs</p>	<p>48</p>  <p>Heat shrink (thick 10cm, for covering the IR sensors) 1 pc</p>	<p>49</p>  <p>7 Pin right-angle male header 1 pc (J1)</p>	
<p>45</p>  <p>LED (orange φ 3mm) 1 pc (LED1)</p>	<p>47</p>  <p>Battery box 2 pcs</p>	<p>48</p>  <p>Heat shrink (thick 10cm, for covering the IR sensors) 1 pc</p>	<p>49</p>  <p>7 Pin right-angle male header 1 pc (J1)</p>	
<p>46</p>  <p>LED (red φ 3mm) 1 pc (LED2)</p>	<p>47</p>  <p>Battery box 2 pcs</p>	<p>48</p>  <p>Heat shrink (thick 10cm, for covering the IR sensors) 1 pc</p>	<p>49</p>  <p>7 Pin right-angle male header 1 pc (J1)</p>	
<p>50</p>  <p>3 Pin male header 8 pcs (J2,J4,J6,J8,J11,J13, J15,J17)</p>	<p>51</p>  <p>2 Pin male header 2 pcs (J9,J18)</p>	<p>52</p>  <p>2 Pin socket 1 pc (BT)</p>	<p>53</p>  <p>DC connector (DC-002) 1 pc (POWER)</p>	<p>54</p>  <p>Switch (SK-12F01P) 1 pc (S1)</p>
<p>55</p>  <p>2 Pin female header 2 pcs (J21,J22)</p>	<p>56</p>  <p>4 Pin female header 2 pcs (J19, J20)</p>	<p>61</p>  <p>Main PCB 1 pc</p>	<p>62</p>  <p>Compound-eye PCB (48mm*30mm) 1 pc</p>	
<p>57</p>  <p>3 Pin female header 8 pcs (J1,J3,J5,J7, J10,J12,J14,J16)</p>	<p>58</p>  <p>Header jumper 2 pcs</p>	<p>59</p>  <p>2 Pin female socket 1pc</p>		<p>60</p>  <p>Crimp connector 2pcs</p>

63

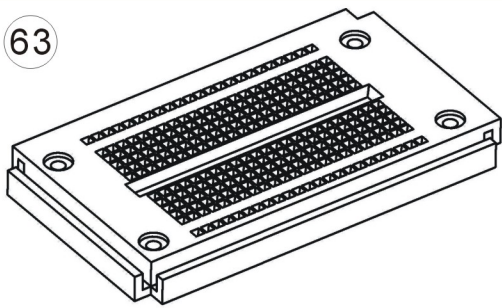

Breadbord (52mm*90mm) 1 pc

64



140 piece cable pack

65

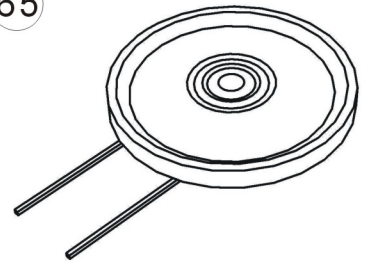

Speaker 1pc

Mechanical Assembly Instructions:

STEP 1: Firstly assemble the 2 PCBs using the following instructions.

IR compound eye

Assembly Instructions:

1. Install the resistors and 7 pin header first.
2. Install the 4 IR LEDs (clear colour) in the center. Be careful of their polarity.
3. Install the PN100 transistor.
4. Install the 8 IR phototransistors (black colour).

Calibration: (should be done at night to reduce ambient IR from sunlight).

1. Connect to 1 digital output and 4 analog inputs of your micro controller.
2. Write code to make digital output high and display analog inputs.
3. Place small pieces of heatshrink (about 3mm wide) on IR LEDs.
4. With sensor facing away from all objects, adjust position of heatshrink so all reading are similar.
5. Place a white object 100mm away from all sensors. Adjust heatshrink if required.
6. When calibrated gently heat the heatshrink so it maintains position on LEDs.

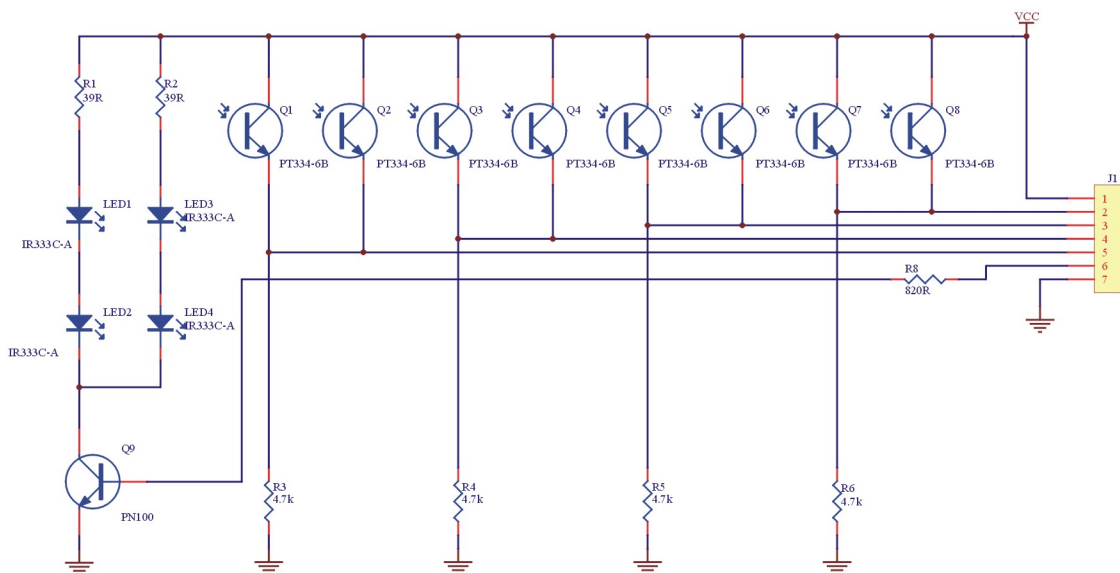
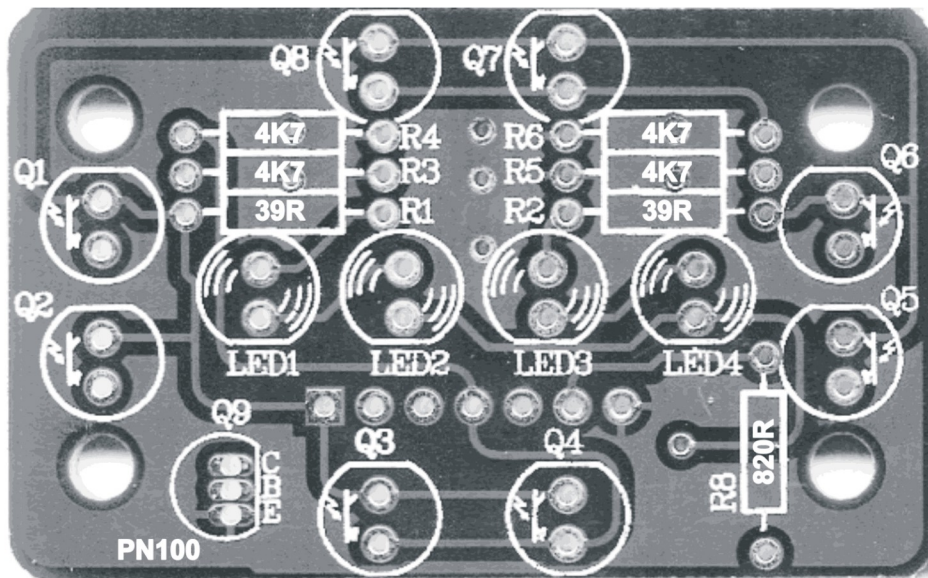

To assemble Mr. Generals PCB, start by inserting components on the top side as shown in the photo. Insert the resistors and diodes first. Take care to orientate the diodes correctly as they are polarised. Insert the transistors and 6 indicator LEDs. Check they are inserted correctly and be careful not to apply too much heat!

Now insert the capacitors, switch and headers.

Note:

J8 and J9 are 2 pin male headers with jumpers. These are used to isolate +V on each side, allowing different voltages to be used.

J21, J22 are 2 pin female header for connecting power to / from the individual voltage rails.

J2, J4, J6, J8, J11, J13, J15, J17 are male headers used for plugging in servos or sensors.

J1, J3, J5, J7, J10, J12, J14, J16 are female headers used for connecting wires from the servos / sensors to the breadboard.

J19, J20 are 4pin female headers used to connect the IR sensors and LEDs to the breadboard.

Now turn the PCB over.

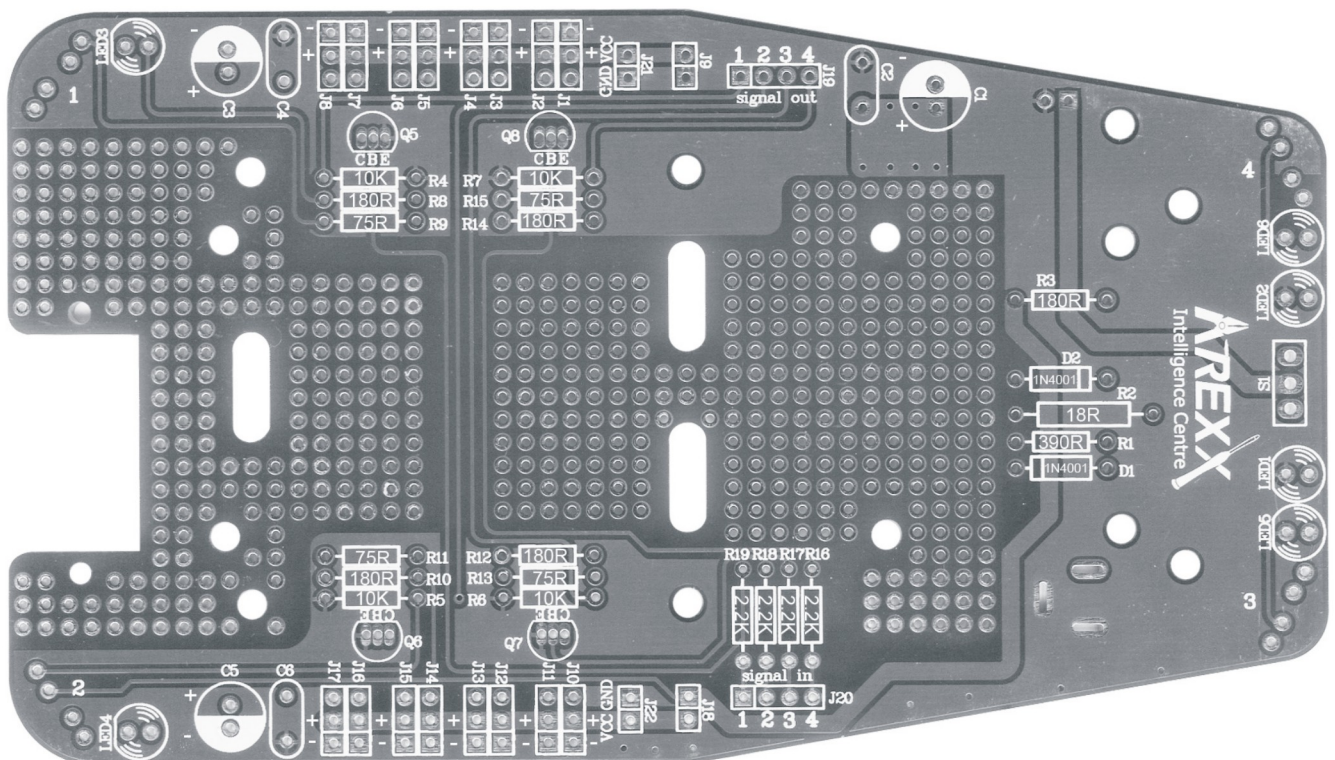

You now need to decide do you want your IR sensors to look outward or downward. If you have your sensors facing outward then Mr. General can use them to avoid running into objects. If you have them facing downward then they can be used to prevent Mr. General from falling over edges or to detect black lines on the ground.

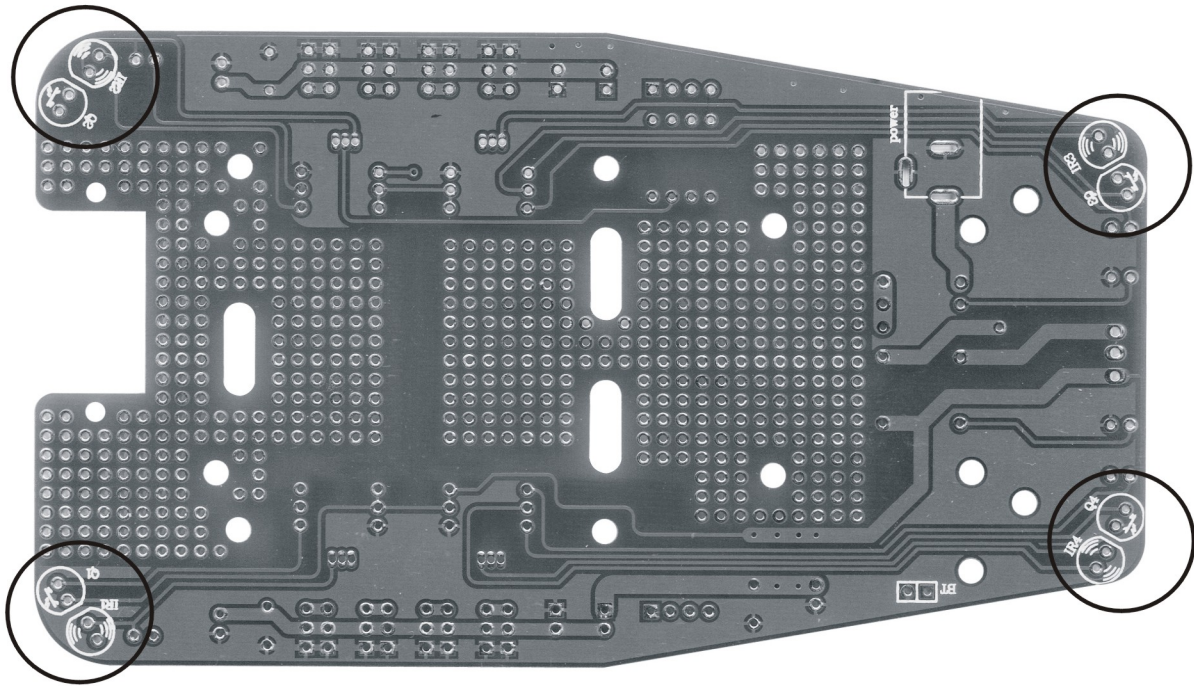
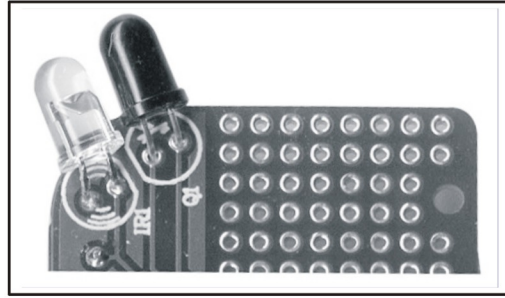
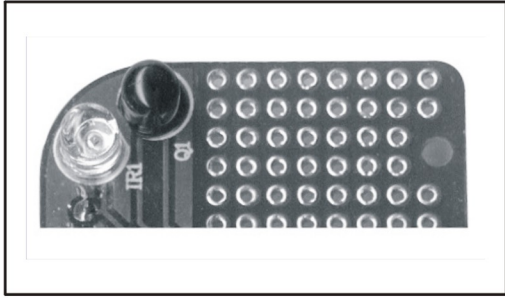

Mount your IR LEDs (clear) and phototransistors (black) to suit. Be carefull to insert them the correct way around otherwise they will not work and may be damaged. Be carefull not to apply too much heat as this can damage them.

Now solder in you power connector and recharge socket(9V DC).

STEP2: Mount the spacer

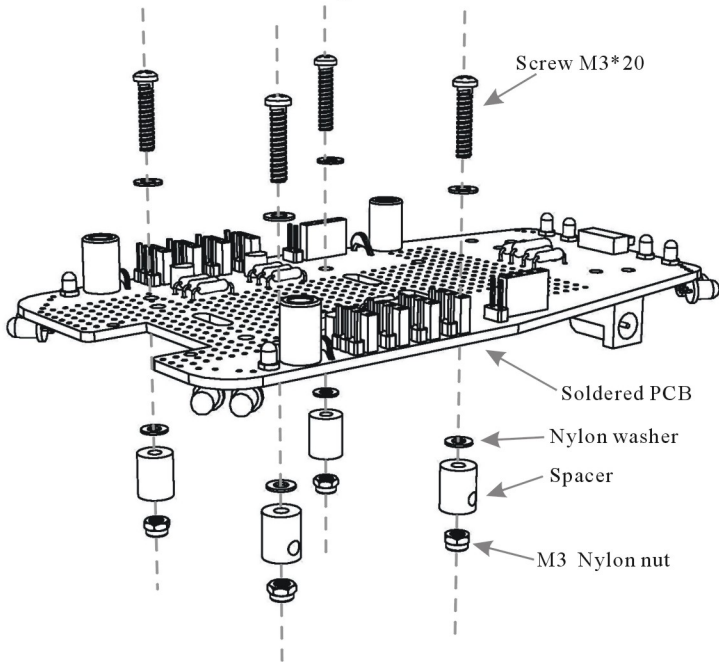

STEP3: Mount modified servos (Both sides)

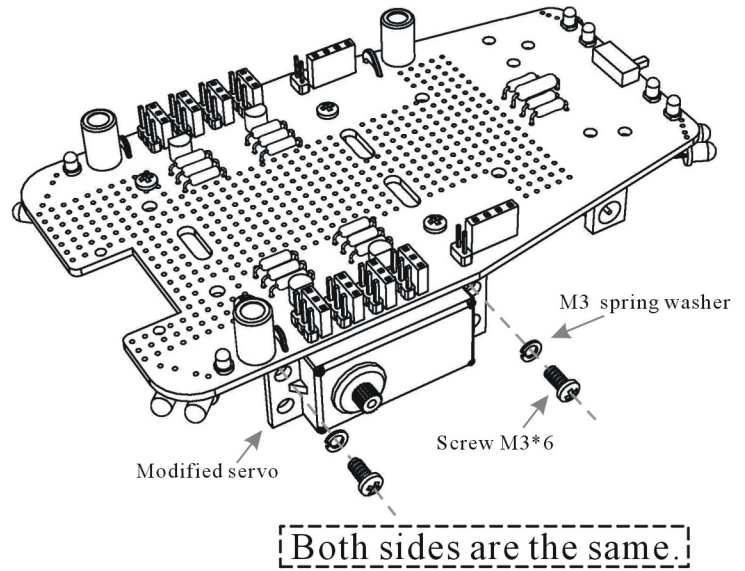

STEP4: Mount the front wheels (Both sides)

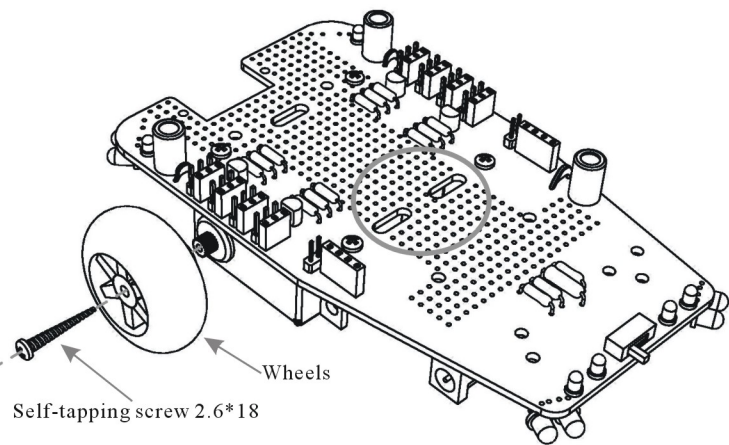

Do not have screw too tight or the wheels will not turn easily!

Both sides are the same.

STEP5: Fit the front breadboard spacers.

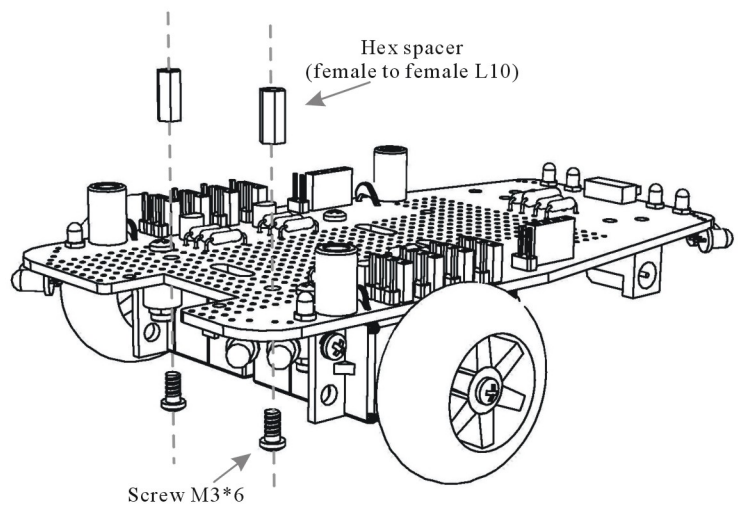

STEP6: Mount the battery on the bottom.

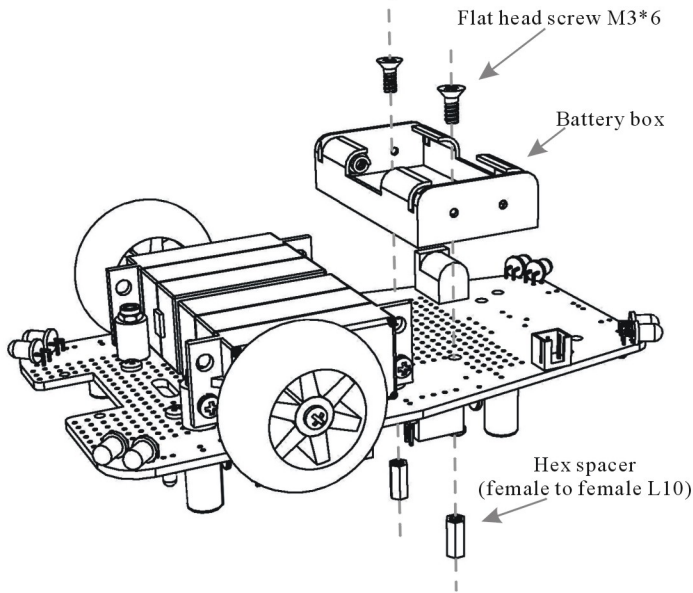

STEP7: Mount the male-female hex spacer

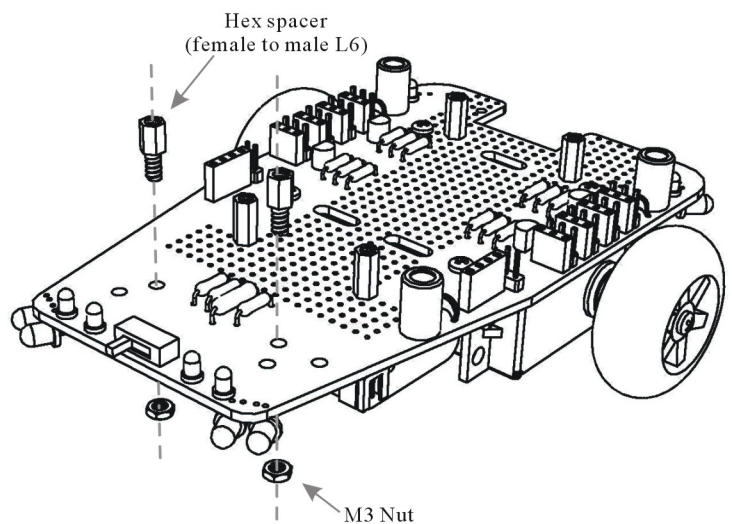

STEP8: Mount the ball caster.

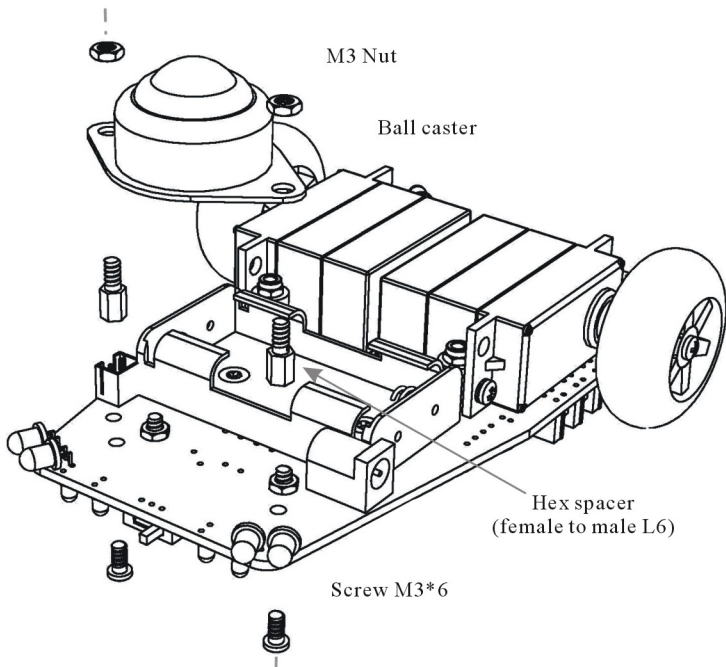

STEP9: Mount the top battery box

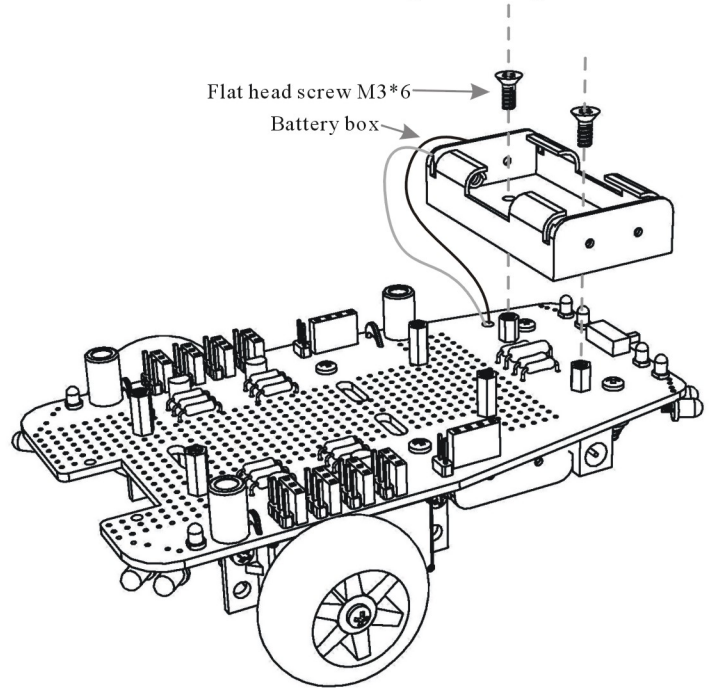

STEP10:

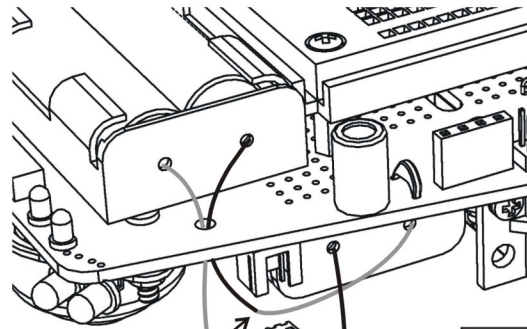
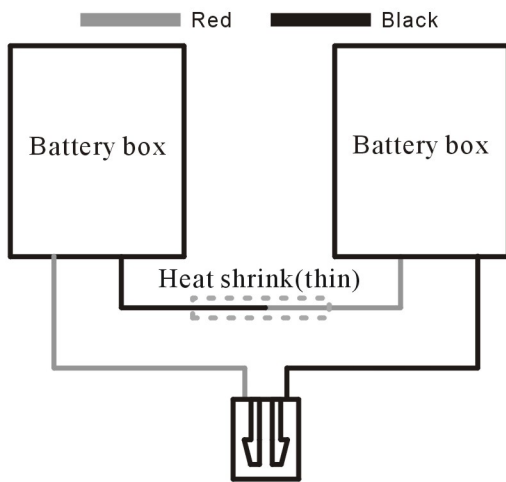

Trim battery wires and solder connections. Take care to connect black and red wires as shown. Reverse polarity will damage the circuitry.

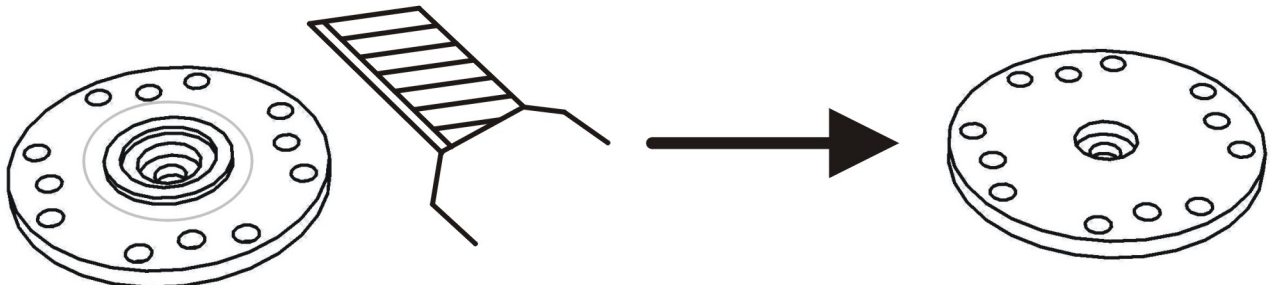
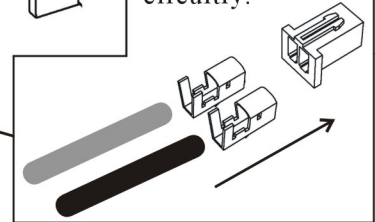

STEP11: Before mount please trim the surface of the servo horn with knife.

STEP12: Rotate the servo with its servo horn, adjust the servo gear to the middle position.

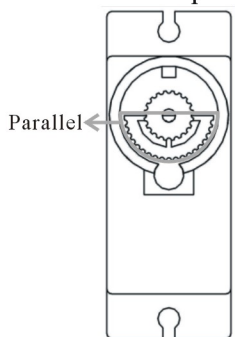

STEP13: Mount the sensor bracket as shown

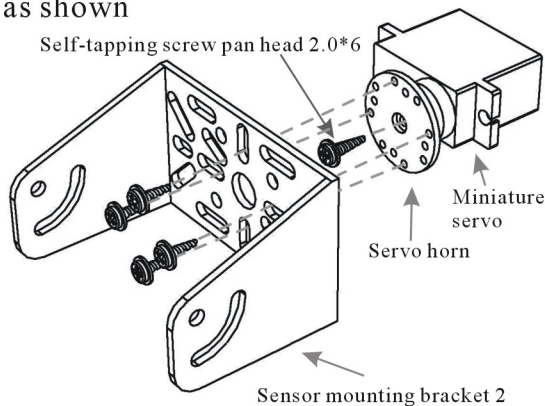

STEP14: Mount the servo mounting bracket

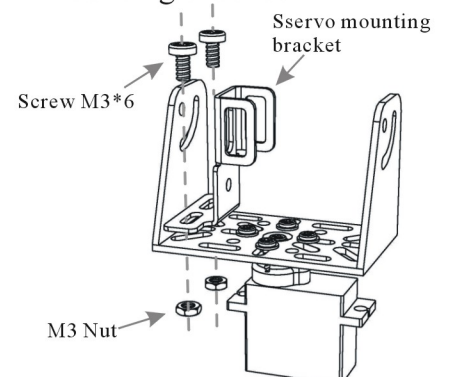

STEP 15: Mount the sensor bracket and miniature servo

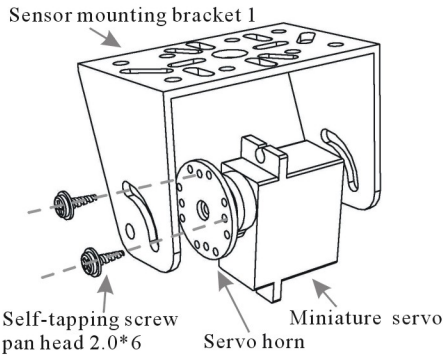

STEP 16: complete pan / tilt assembly

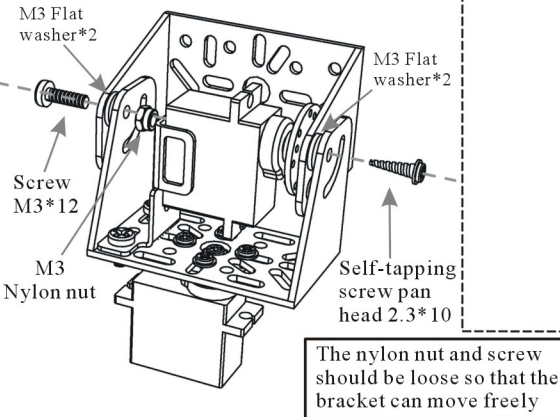

STEP17: Mount pan / tilt assembly on the main PCB

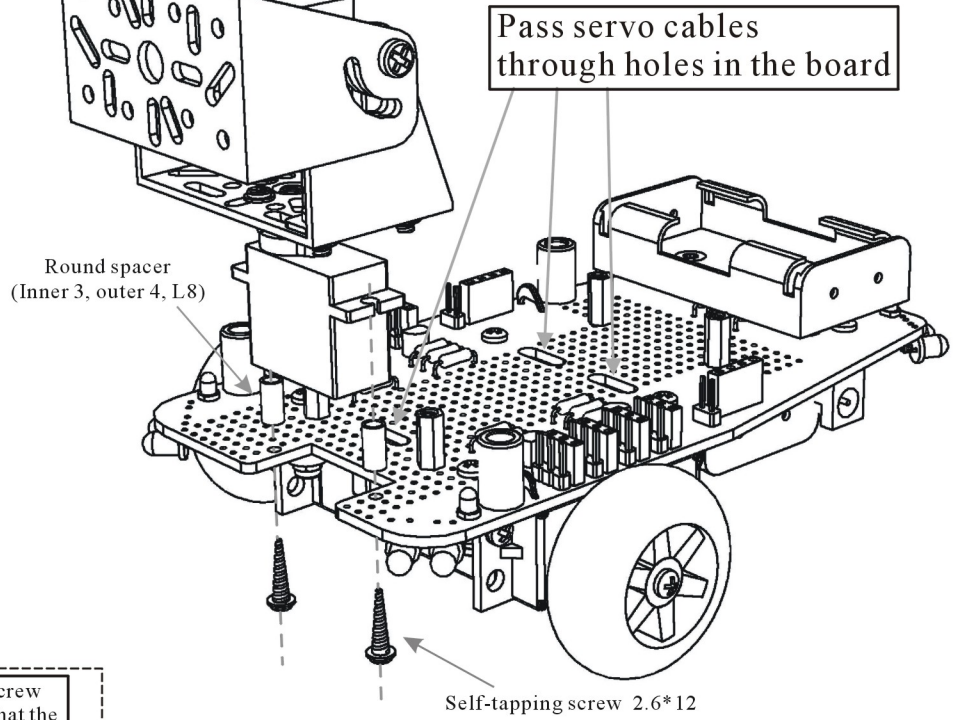

STEP18:Mount the breadboard.

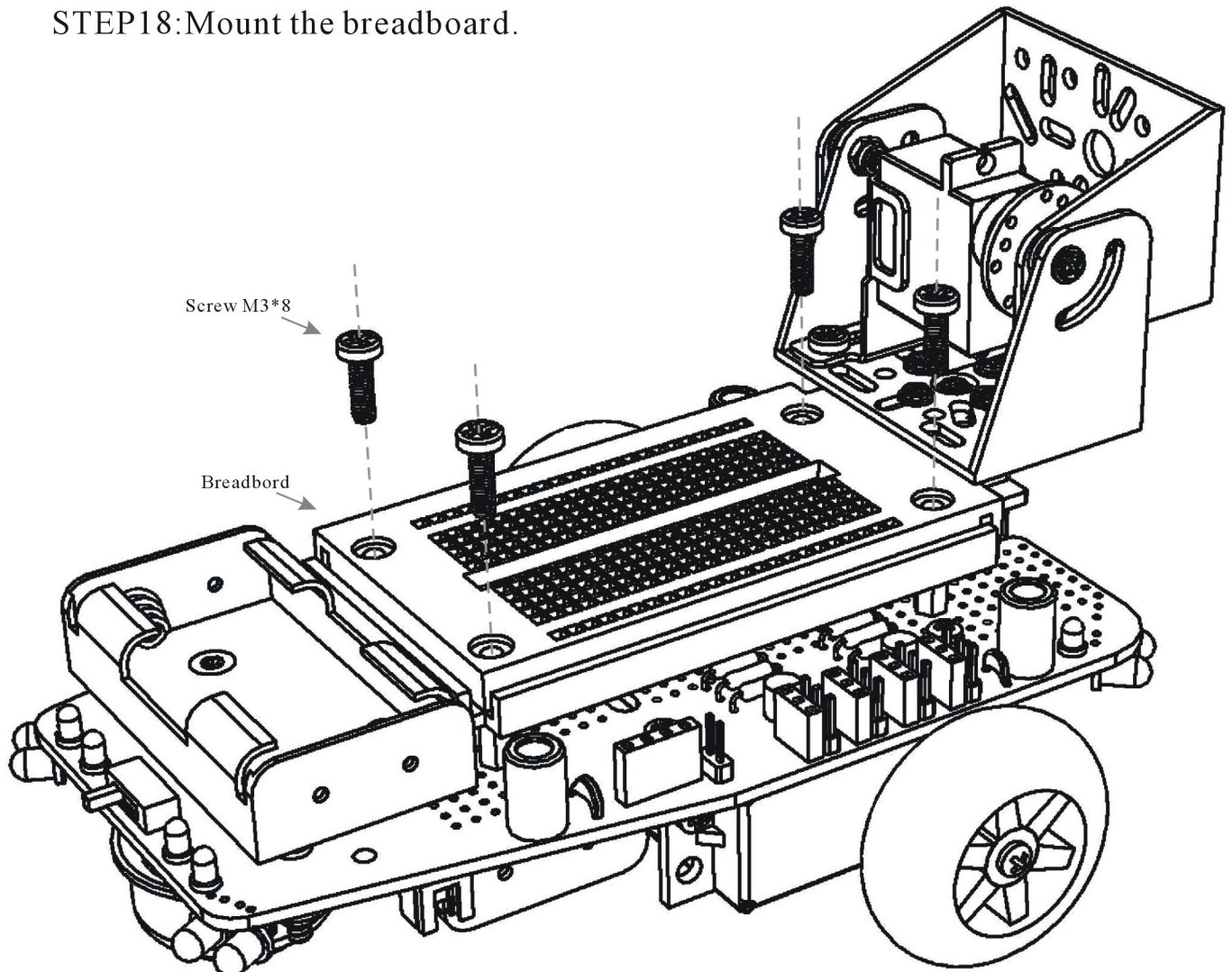

STEP19:Mount the sensor PCB.

The four screws should be fixed with four nuts.

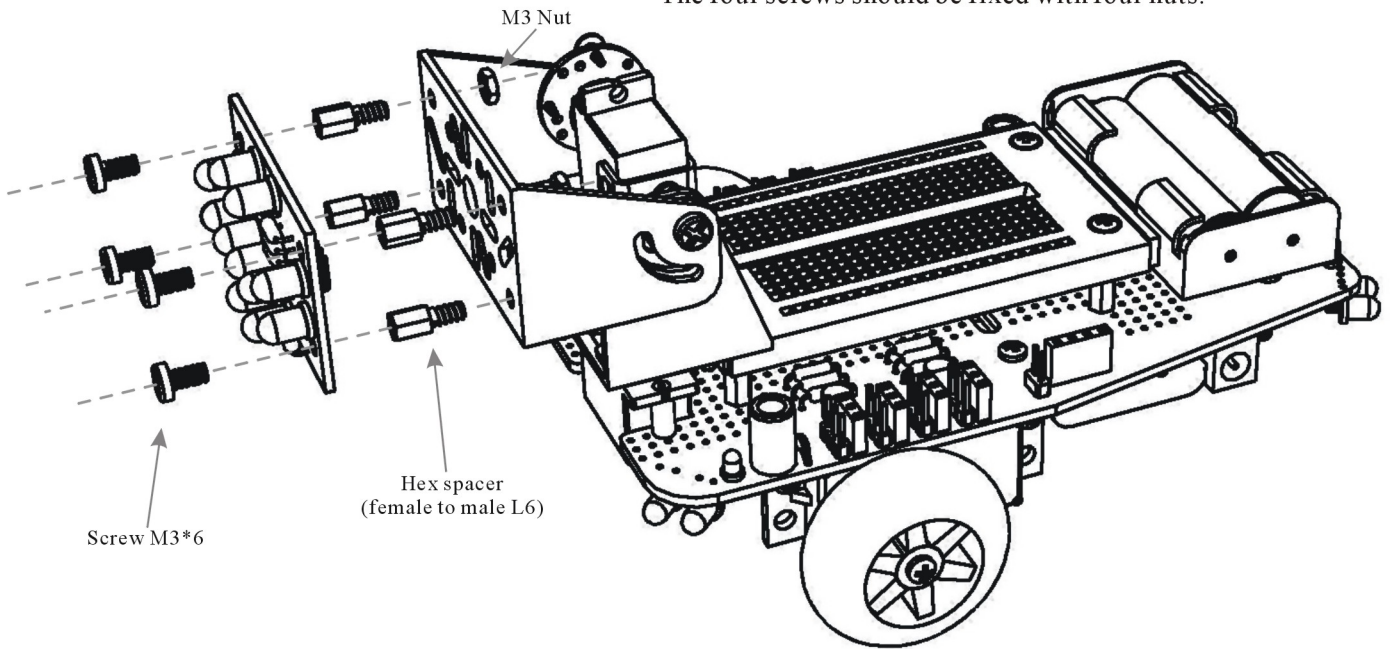

Now add your processor and connect it with the cables provided.

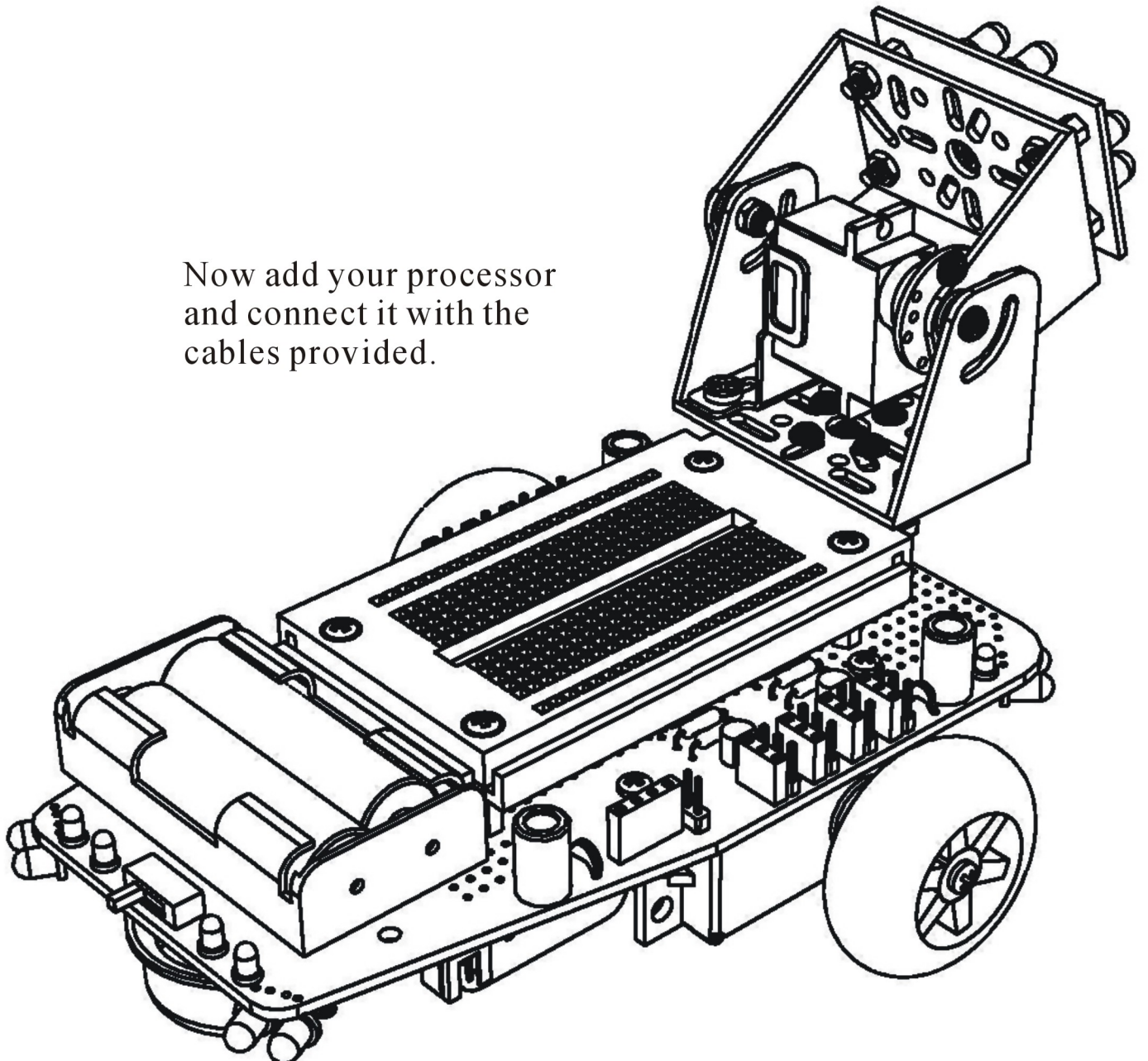

Main PCB

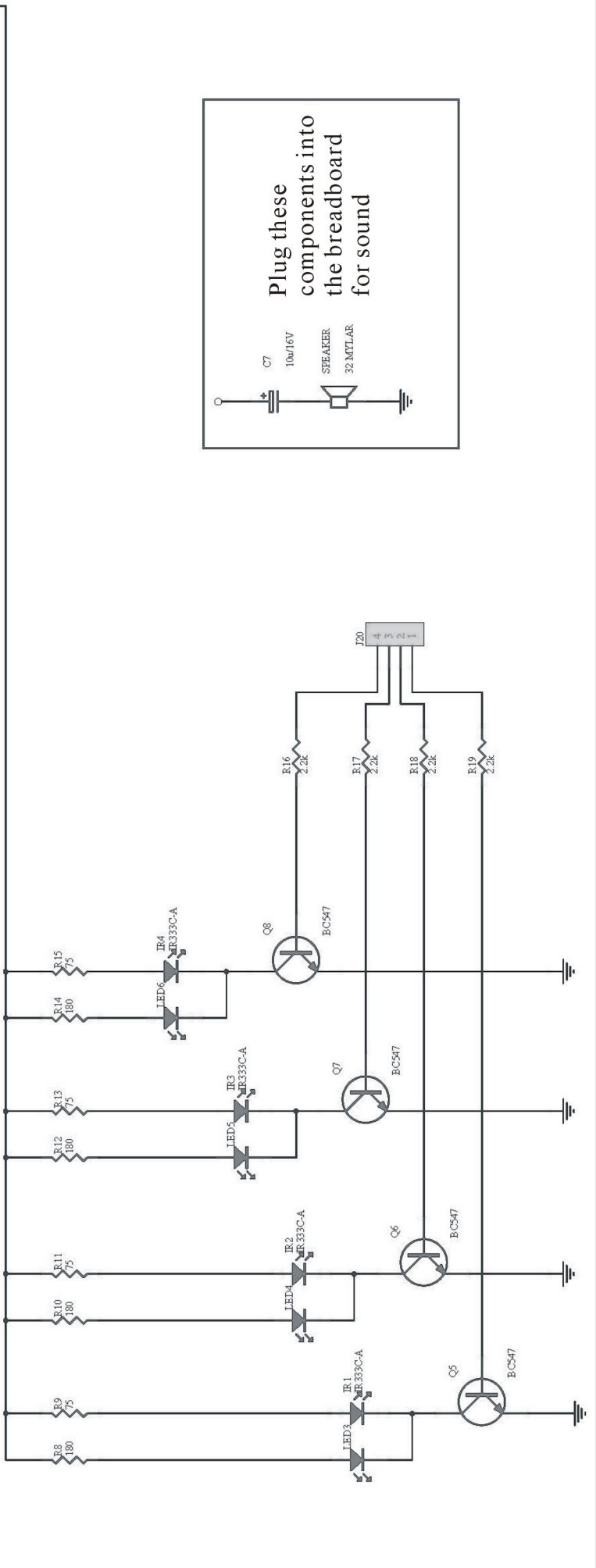
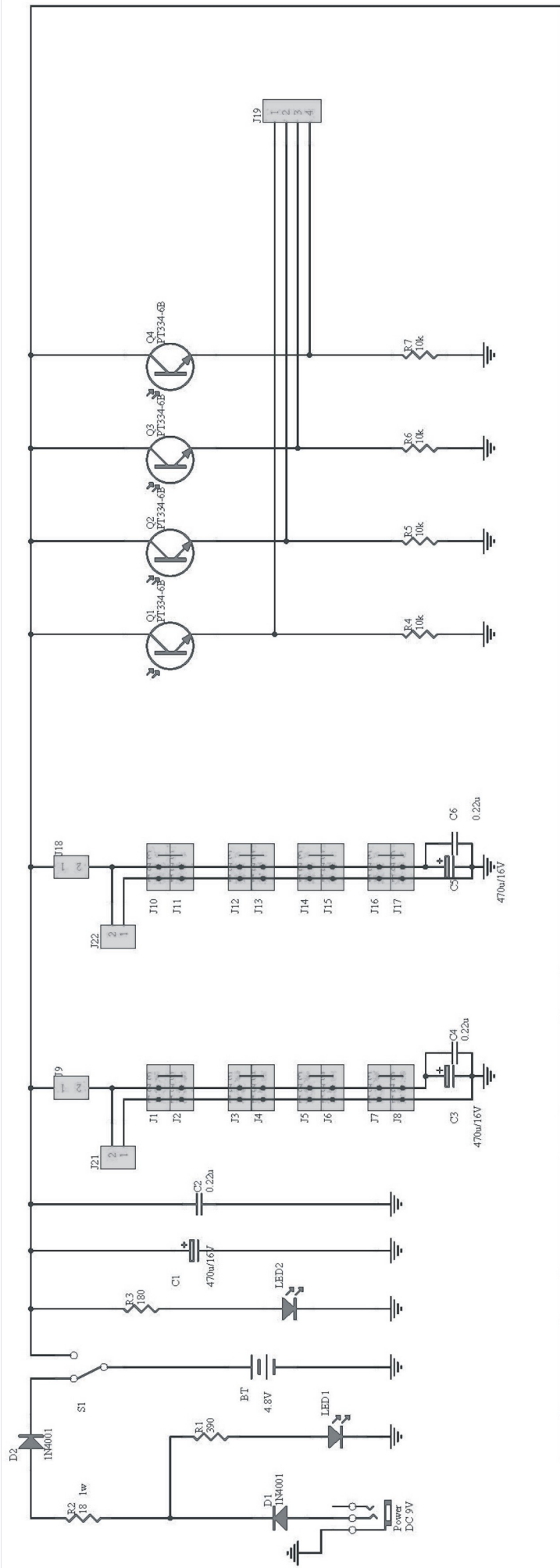

Plug these components into the breadboard for sound

C7 10uF/16V
 SPEAKER 32 MLTAR

Compound-eye PCB

